

# ELECTROLUX

*HIGH SPEED GRILL - Panini*

**HSG *Panini***

*Thinking of you*

 **Electrolux**

# Innovation

## Main Advantages



### High Speed & Quality Panini Grill



- **SPEED.** Up to 6 times faster than a standard sandwich grill with the highest quality and record times.
- **QUALITY.** Higher Food Quality in terms of sensorial properties (taste, grill marks, crispiness, flavour..) and nutritional value (vitamins & proteins preservation).
- **REPEATABILITY** of the quality result in every condition. The HSG will do the job automatically for you without any risk of quality change due to the operator actions.
- **FLEXIBILITY.** 1 step process. With a unique machine in one step solution we can start from refrigerated sandwiches and get them perfectly toasted and warm in their core in few seconds. No need to combine different appliances.

# Innovation

## Main Advantages

*Thinking of you*

 **Electrolux**

- **TECHNOLOGY MADE SIMPLE.** Place your sandwich on the cooking surface and close the lid. The HSG will adapt itself the top grilling plate and open automatically the lid for you when the sandwich is ready.



- **ENERGY SAVING** (Stand by mode) After 5 minutes of non operation, the HSG will automatically enter in “energy saving mode”. If you decide to cook another pannini, just open the lid and choose the program. There is no need to wait for preheating.

# Innovation

## Performance

*Thinking of you*  
**Electrolux**



**HSG** *panini*

- **Various types of food**
  - Hot sandwiches (bread, meat, cheese, vegetables, dressing)
  - Roll up
  - Tacos. burritos
  - etc.
- **Performance** (internal tests)
  - Starting Temp.= 4°C (refrigerated)
  - Target core Temp.  $\geq 60^{\circ}\text{C}$
  - Food mass: 250grams
  - Cooking time:  $< 40$  seconds
  - Toasted bread with grill marks on the outside

# SPEED AND QUALITY !

## Warm and crispy in record time !

*Thinking of you*

**Electrolux**

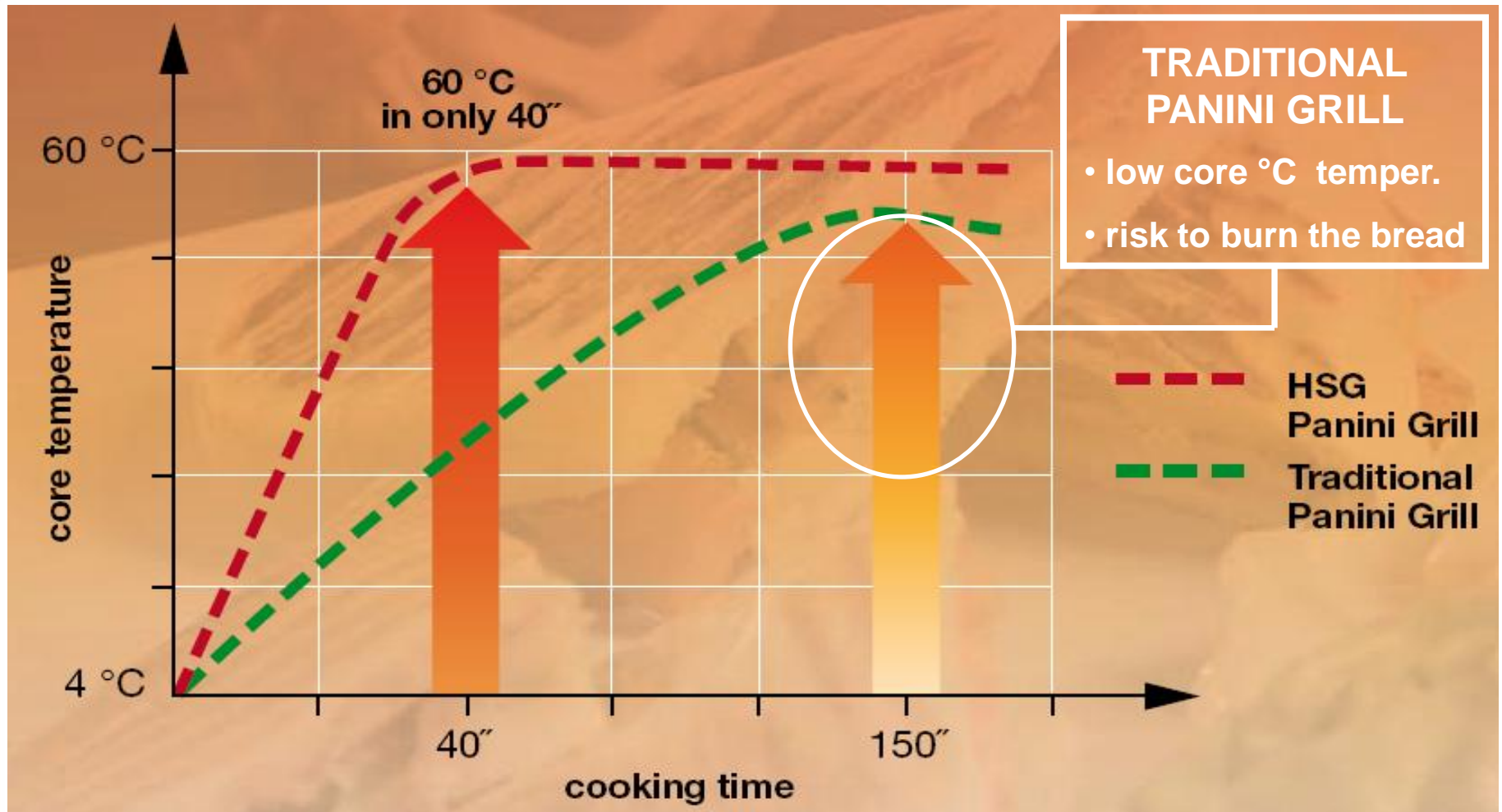

# Innovation

## Features

*Thinking of you*  
**Electrolux**

**HSG** *panini*



## Innovative features

- Combination of 3 heating modes:
  - Contact plates
  - Infrared radiation
  - Microwaves
- Self adjusting upper plate
- Automatic holding and opening once the cycle ends with countdown
- Beeps at the end of the cycle
- Programmable electronic control
- Energy saving mode

# Combination of 3 different heating sources

Thinking of you  
**Electrolux**

**HSG** panini

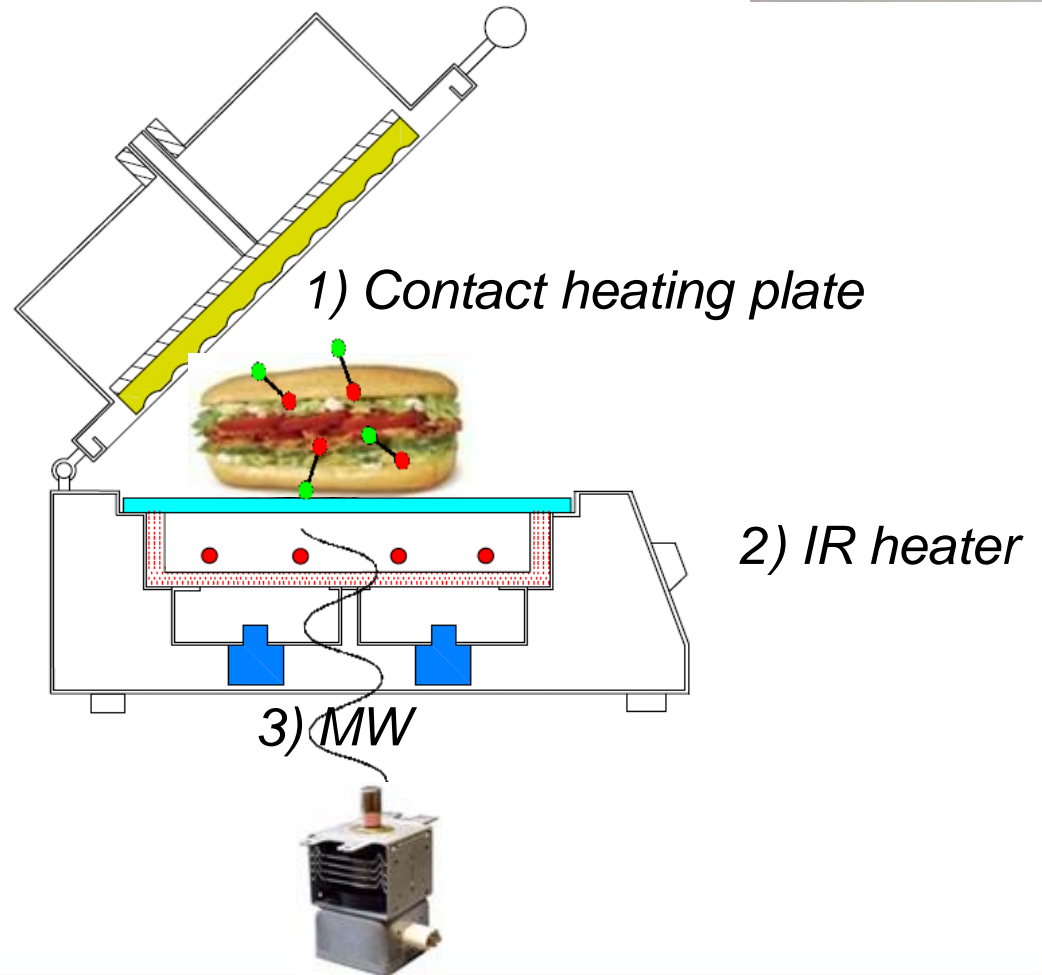

# Combination of 3 different heating sources

*Thinking of you*  
**Electrolux**

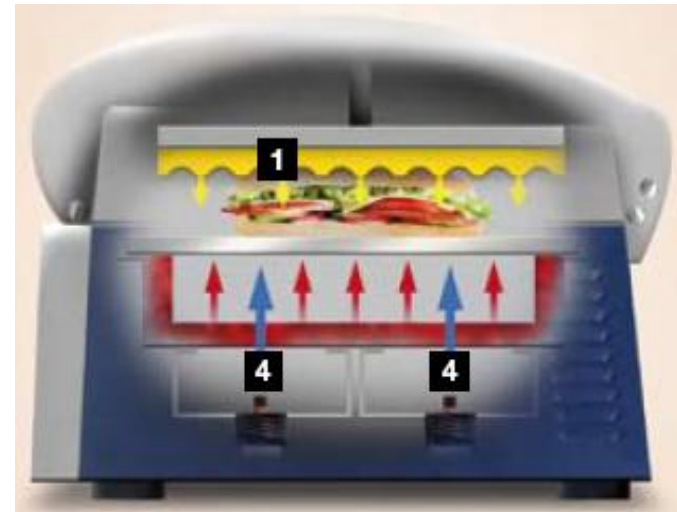
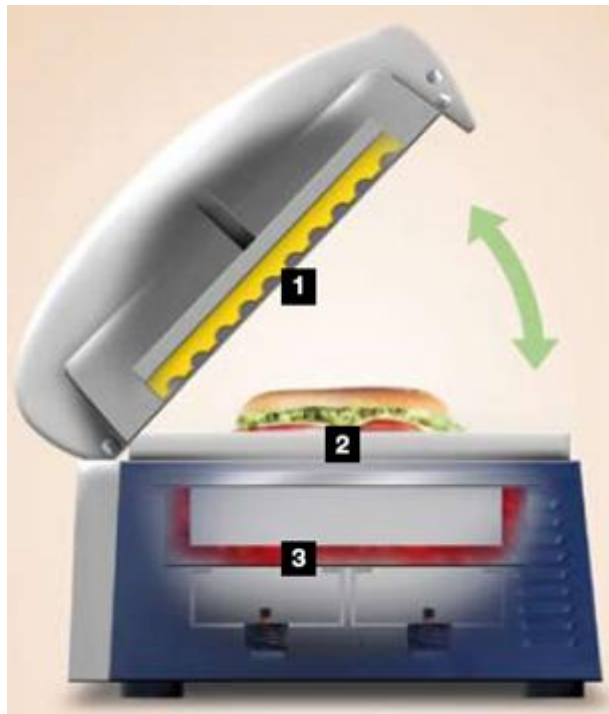

- 1. Contact heating plate:** perfect grill marks for an appetizing presentation.
- 2. Glass quartz plate:** cleaning is very easy.
- 3. Infrared heater:** delicious crispy sandwiches in record times.
- 4. Microwave:** warm inside and out. Serve only the best.



# Top and bottom plate

*Thinking of you*  
**Electrolux**

## TOP PLATE



- Aluminium Ribbed plate
- Dimension 215 x 215 mm
- Temperature up to 250 °C for perfect marks

## BOTTOM PLATE

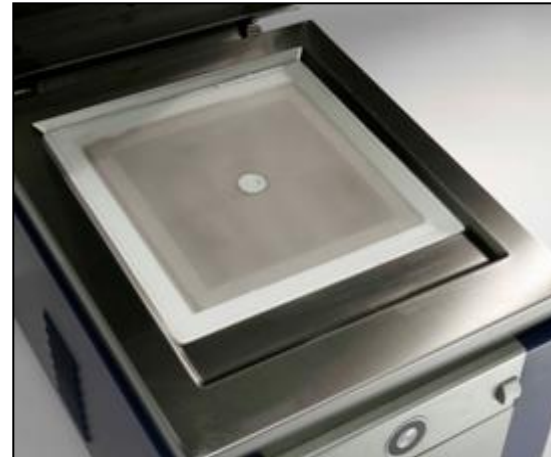

- Glass quartz smooth plate
- Dimension 250 x 250 mm (net cooking area 215 x 215 mm)
- Temperature up to 230 °C

**HSG** panini

# Self adjusting upper plate

*Thinking of you*

**Electrolux**

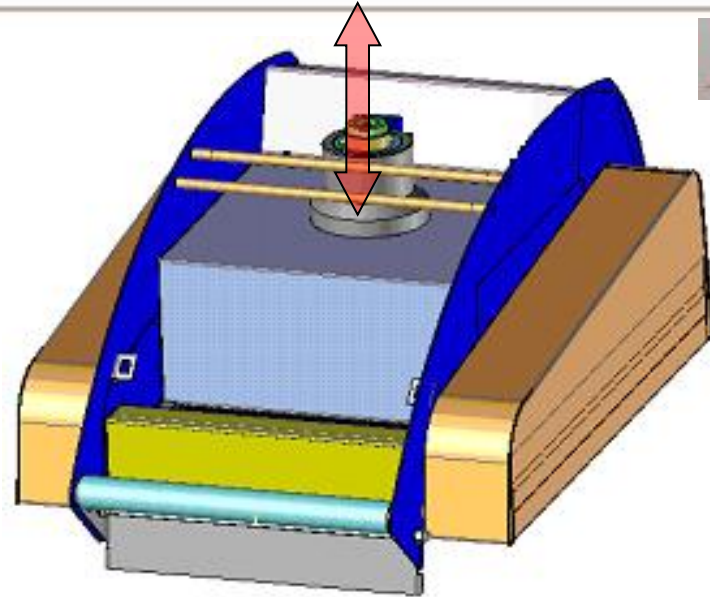

**HSG** *panini*

- Upper plate self height adjustable:  
(from 1 to 7.50 cm)
- Pressure given automatically to sandwich without any action required by the operator.

# Automatic holding and opening system

*Thinking of you*  
**Electrolux**

**HSG** panini

1. Automatic holding system during cooking phase (upper lid closed)
2. Automatic de-activation of the holding system at the end of the cooking phase (upper lid open)



3. Machine re-start when the lid has been closed.

# Automatic holding and opening system

*Thinking of you*  
Electrolux

The holding system is controlled by an electro magnet that is activated when the lid is closed and de-activated as soon as the cooking cycle ends (countdown). The lid lifts **automatically** at the end of the cycle.

HSG panini



**ELECTRO  
MAGNET**

# Steam evacuation

*Thinking of you*  
**Electrolux**

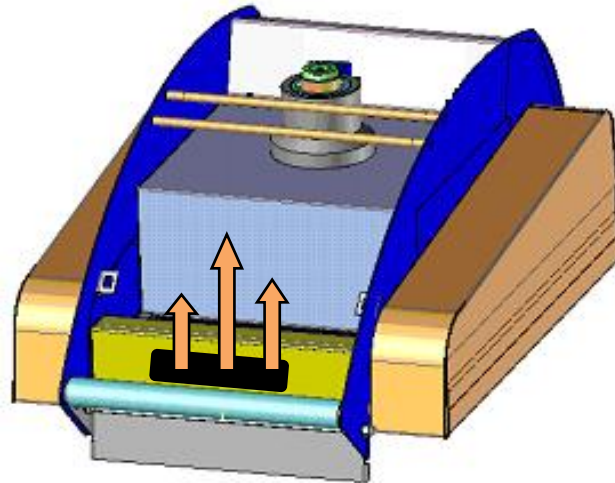
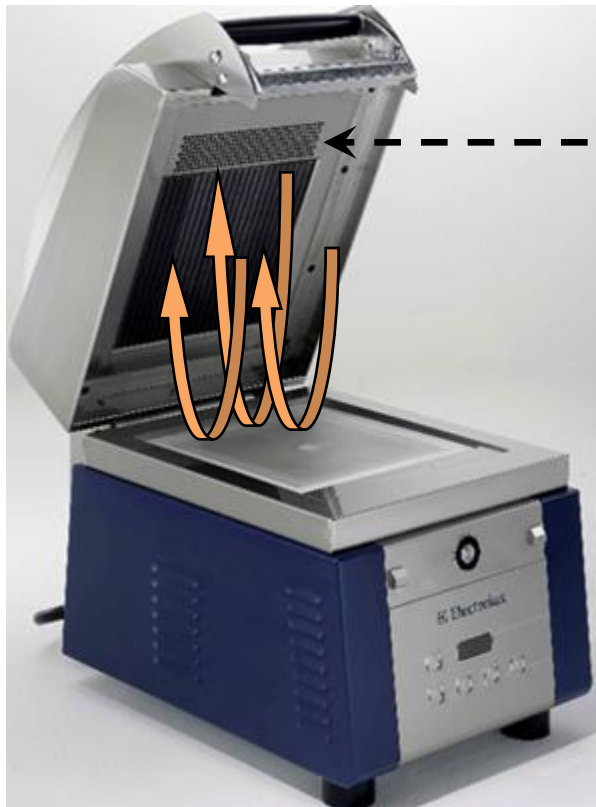

The gaseous emission produced during the cooking cycle



Escape through a grid present inside the upper lid



And the steam is evacuated by natural chimney flow

# LED digital display

*Thinking of you*  
**Electrolux**



**Electronic controls  
with LED digital display**

Up to 4 different  
programs/cooking cycles\*

- Display of the program selected
- Display of the countdown

\* The preset programs are adjustable/programmable. US and International model have different pre set programs.

# Some examples in 30 seconds ?

*Thinking of you*  
**Electrolux**

Program 1 - Total time 30" (including 20" MW) - International model



**Bread type:** arabic bread

**Ingredients:** bread, black pepper, dried tomatoes (julienne cut), crispy bacon, mayonnaise, bread.



**Bread type:** focaccia

**Ingredients:** bread, mayonnaise, sliced hot dog, swiss cheese, bread

# Some examples in 40 seconds ?

- Program 2 - Total time 40" (including 30" MW) - International model



**Bread type:** bagel

**Ingredients:** bread, mustard, smoked provolone cheese, dried tomatoes, crispy bacon, sliced turkey, mayonnaise, bread.



**Bread type:** french bread

**Ingredients:** bread, cream cheese, grilled peppers, grilled zucchini, grilled eggplants, mayonnaise, bread



# Some examples in 50 seconds ?

- Program 3 - Total time 50" (including 40" MW) - International model



**Bread type:** sliced rye bread  
**Ingredients:** bread, mushroom sauce, roast-beef, mushrooms, brie cheese, mayonnaise, bread.



**Bread type:** rosemary focaccia  
**Ingredients:** bread, mozzarella cheese (julienne cut), pesto, tropea onions, grilled chicken breast, sliced tomatoes, mayonnaise, bread.

# Starting kit (included)

*Thinking of you*

**Electrolux**



**30 BAKING PAPER SHEETS**  
(to be used for the top plate and changed once per day)



**SILICONE SPATULA**  
(to load and unload the sandwiches from the appliance)



**SCRAPER**  
(to remove food residual from the bottom plate)



**CLEANING PROCEDURE CARDS**

## TEFLON BRUSH

(to be used on the top plate if, despite the use of the baking paper, it should get dirty)



## HIGH TEMPERATURE DEGREASER

(to be used on the hot surface at the end of the service during cleaning procedure)



# Programmable electronic control

*Thinking of you*  
**Electrolux**

**HSG** panini



## Programmable parameters

- Top plate temperature \*
- Bottom plate temperature \*
- Total cycle duration
- Microwave duration

+ The temperature will remain the same for all the 4 programs

# Calculations / Backflow

*Thinking of you*

 **Electrolux**

	Expenses - ingrediences (€)	Selling price (€)	Pieces / day	Income / Day (€)	Energy cons. (kWh)	Price (0,168,- € / kWh)	Gain / day (€)	Gain / year (€)	Backflow - price of HSG 4500,-€ without tax (days)
<b>Foccacina with meat loaf</b>	1,052	2,52	50	126,1	7	1,2	72,27	26 379,1	62
	1,052	2,52	100	252,1	12	2,0	144,88	52 880,9	31
	1,052	2,52	150	378,2	17	2,9	217,49	79 382,7	21
	1,052	2,52	200	504,2	22	3,7	290,09	105 884,5	16
	1,052	2,52	300	756,3	27	4,5	436,15	159 194,8	10
<b>Panini with mozzarella</b>	0,705	2,10	50	105,0	7	1,2	68,64	25 053,5	66
	0,705	2,10	100	210,1	12	2,0	137,62	50 229,8	33
	0,705	2,10	150	315,1	17	2,9	206,59	75 406,0	22
	0,705	2,10	200	420,2	22	3,7	275,57	100 582,2	16
	0,705	2,10	300	630,3	27	4,5	414,36	151 241,4	11
<b>Cheese nigela</b>	0,843	2,10	50	105,0	7	1,2	61,70	22 521,3	73
	0,843	2,10	100	210,1	12	2,0	123,74	45 165,3	36
	0,843	2,10	150	315,1	17	2,9	185,78	67 809,3	24
	0,843	2,10	200	420,2	22	3,7	247,82	90 453,2	18
	0,843	2,10	300	630,3	27	4,5	372,73	136 047,9	12

**All prices are considered without VAT.**

# HSG Panini

*Thinking of you*

 **Electrolux**

**HSG** *panini*

# Thank you!